

FILM BASED PORTABLE X-RAY SYSTEMS

sri
source-ray, inc.

Model: SR-115

- High Power Output (1.5 kW)
- 100 kV, 15 mA, 60 mAs
- High Frequency
- Microprocessor Control
- Light Weight /Very Agile
- Cost Effective
- Designed for Reliability
- Durable Powder Coat Finish
- Limited 3 year Warranty



Model: SR-130

- Higher Power Output (3.0 kW)
- 100 kV, 30 mA, 120 mAs
- High Frequency
- Microprocessor Control
- CR/DR Compatible
- Light Weight
- Designed for Reliability
- Durable Powder Coat Finish
- Limited 3 year warranty



FILM BASED PORTABLE X-RAY SYSTEMS

The SR-115 was designed to focus on a price sensitive market that addresses cost containment goals for radiology capital equipment purchases in the portable x-ray market place. Developed for clinicians who are satisfied using lower powered x-ray units and who will continue using traditional film screen systems. The SR-115 is a user friendly system designed for high reliability, and the durability required for the Diagnostic Outreach Market. Providing state of the art technology, the SR-115 produces 1.5 kW of power. It's 80 lb. net weight makes it the lightest portable x-ray

system on the market today. The SR-115 weighs significantly less than other systems that produce less output. It provides clinicians invaluable maneuverability and agility around beds and other essential equipment in tight areas where space is at a premium, especially in private homes. Utilizing a small foot print, the SR-115 is an ideal system to transport in small vehicles that are economically viable for Diagnostic Outreach Services. The SR-115 can be used in clinics, nursing homes, private homes, orthopedic practices, sports medicine and correctional facilities.



(Complies with CFR 21 Subchapter J)

The SR-130 provides higher power, state of the art technology, system reliability and low maintenance, all in a small footprint, lightweight package.

The SR-130 was designed with agility in mind. It's compact, lightweight construction makes it easy for the operator to move the system effortlessly. Delivering maximum mR/mAs, the SR-130 produces 3 kW of power that provides hospital quality imaging, performed anywhere, anytime a Portable X-Ray System is transported to a patient. With it's 3 kW output power, the SR-130 is an ideal system for organizations

considering the purchase of a CR-System. CR-Systems currently operate at 200 speed. The SR-130 provides the power required to compensate for this slower operating speed without compromising image quality. The SR-130 is a user friendly system designed for high reliability and the durability required for the Diagnostic Outreach market. The SR-130 can be used in hospitals, clinics, nursing homes, private homes, orthopedic practices, sports medicine, correctional facilities and military field deployable applications.



(Complies with CFR 21 Subchapter J)



Generator

Input Voltage
kVp Range

mA Range

mAs Range
Indicators

High frequency resonant inverter – 1.5 kW
115/230 VAC, 50/60Hz
40 – 100 kVp, adjustable in 1 kV increments - closed loop regulation
Fixed, 15 mA - closed loop regulation
0.15 - 60
Digital display of kVp and mAs.
X-Ray, Ready and Fault indicators.
Detachable two-position

Exposure Switch

X-Ray Tube

Filtration
Target Material
Anode Capacity
Focal Spot
Target Angle

Stationary Anode 100 kVp
2.7 mm al minimum
Tungsten
20,000 HU Storage
1.0 mm
15°

Collimator

Tape Measure
Inclinometer

Advantech R72/32-ET
SID Measurement
Angle Measurement

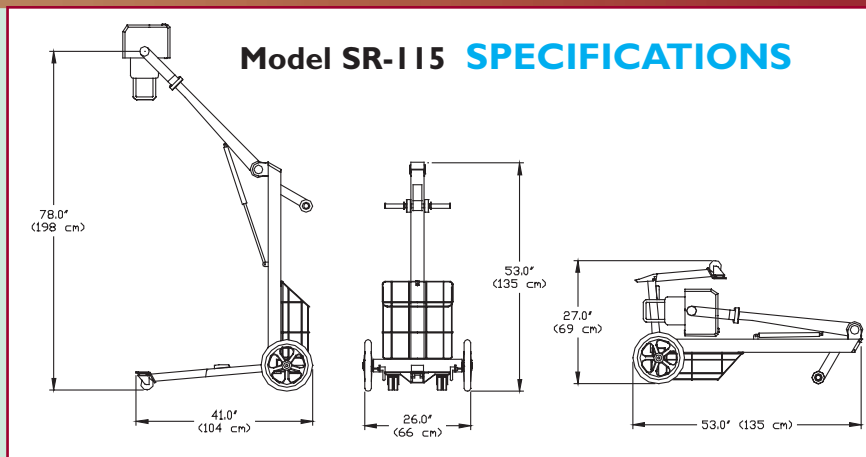

Travel Stand

Min. F/S to Floor 13" / 33 cm
Max. F/S to Floor 78" / 198 cm
Hor. Ext. of F/S 21" / 53 cm
Hor. Rotation 200°
Tube Rotation 270°

System Weight

80 lbs. / 36 kG

Generator

Input Voltage
kVp Range

mA Range

mAs Range
Exposure Time
Indicators

High frequency resonant inverter – 3.0 kW
115/230 VAC, 50/60Hz
40 – 100 kVp, adjustable in 1 kV increments - closed loop regulation
Fixed, 15 mA and 30 mA - closed loop regulation
0.15 - 120
0.01 – 4.00 seconds
Digital display of kVp, mAs and Time. X-Ray, Ready, mA Station and Fault indicators.
Detachable two-position

Exposure Switch

X-Ray Tube

Filtration
Target Material
Anode Capacity
Focal Spot
Target Angle

Stationary Anode 110 kVp
2.7 mm al minimum
Tungsten
30,000 HU Storage
1.0 mm
15°
Advantech R72/32-ET
SID Measurement
Angle Measurement

Collimator

Tape Measure
Inclinometer

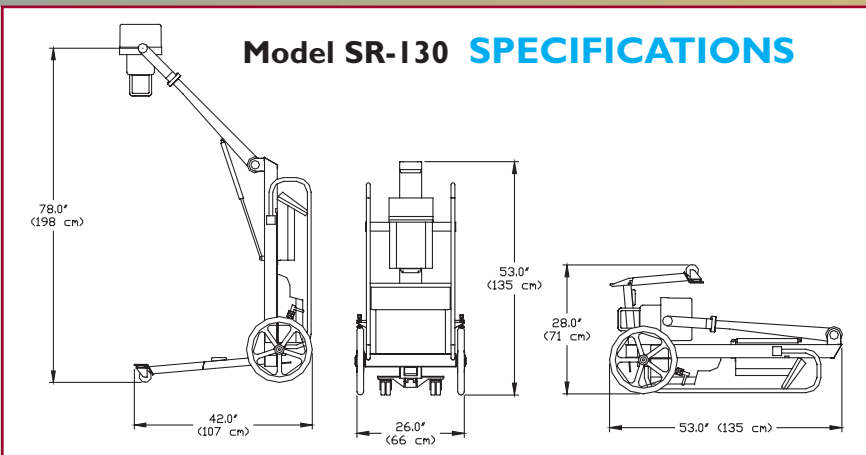

Travel Stand

Min. F/S to Floor 13" / 33 cm
Max. F/S to Floor 78" / 198 cm
Hor. Ext. of F/S 21" / 53 cm
Hor. Rotation 200°
Tube Rotation 270°

System Weight

100 lbs. / 45 kG

Specifications are subject to change without notice.

Names of companies and/or products appearing in this document are trademarks and /or registered trademarks for their respective companies.

sri
source-ray, inc.

Source-Ray, Inc. • 167 Keyland Court • Bohemia, NY 11716
(631) 244-8200 • Email: sales@sourceray.com • fax (631) 244-7464